



USG Fire Rated Exposed Grid Ceiling System

IN THE EVENT OF
FIRE, DO NOT USE
THE ELEVATOR
USE THE STAIRS

General Offices

Hotels

Retail Malls

Banks

Reception/lobbies

Board Rooms

Showrooms

Education

Medical

Industrial

Food Preparation Areas

USG DONN brand suspension systems are the original exposed grid system developed in the 1950's and still a world leader in technology and innovation.

In addition to standard exposed grid acoustical ceiling systems, for fire protection and safety, USG DONN DXL grid system combined with the appropriate USG Firecode acoustical ceiling panel can provide a number of different Fire Resistant Rating (FRR/FRL) ceiling design options up to 60/60/60.

This provides the benefits of acoustic control not possible with plasterboard systems, fire and seismic safety, visual options and economy. Additionally as a total ceiling system, USG exposed grid and USG acoustic ceiling panels are covered by a Lifetime Warranty (up to a maximum of 30 years).



One system, for fire and acoustics

Standards and Building Codes

USG uses the following Standards in its manufacturing, testing and marketing policies for compliance with the respective Building Codes of Australia and New Zealand

AS/NZS 2785	- Suspended Ceilings, Design and Installation
ASTM C635	- Standard Specification for the Manufacture, Performance and Testing of Metal Suspension Systems for Acoustical Tile and Lay-in Panel Ceilings
AS/NZS 1397	- Steel Sheet and Strip
AS/NZS 1530.3	- Methods for fire tests on building materials, components and structures.
AS 1530.4	- Fire Resistance of Elements of Building Construction
AS/NZS 3837	- Method of test for heat and smoke release rates for materials and products using an oxygen consumption calorimeter (cone test)
AS/NZS 4600	- Cold Formed Steel Structures Code
AS 1170.4	- Earthquake Loads (Australia)
NZS 1170.5	- Earthquake Loads (New Zealand)
NZS 4219	- Specification for Seismic Resistance of Engineered Systems in Buildings
AS 2946	- Suspended Ceilings, Recessed Luminaires and Air Diffusers Interface
NZBC – B1/VM1	- NZ Building Code Verification Method B1/VM1 Clause 2
NZBC – B2 Durability	- DONN DXL will have a minimum serviceable life of 15 years when installed in a dry, non-corrosive, interior installation

ISO 9000 Quality Assurance

USG Interiors Pacific Ltd is an accredited ISO 9001 – 2008 manufacturer
Licence No. 5044



Quality
ISO 9001





Users Guide

ADVANTAGES of DONN Brand Fire Rated Grid

A fire rated ceiling helps prevent fire and/or heat from reaching a floor or roof above a room that is on fire. This allows time for evacuation of the floors above and protects against property damage. A fire rated ceiling system is part of a total fire rated assembly, which includes approved beams, joists and floor or roof assemblies.

- BRANZ tested to AS1530.4 Fire Resistant Tests of Elements of Building Construction (full copy available on request)
- Exclusive expansion notch in main tee is designed for controlled collapse in the event of fire, ensuring integrity of the ceiling plane
- Heavy weight tees resist buckling, longer
- Visually identical to standard USG DONN Brand 24mm exposed grid where the same image is required in non-fire rated areas
- High density USG Firecode ceiling panels provide choices of size, appearance and acoustical properties to suit a range of applications
- Plus all the fast, easy installation features of standard DONN DX exposed grid systems

Contents

	Page
DONN DXL Fire Rated Grid	4
USG Firecode Acoustical Ceiling Panels	4
Floor/Ceiling Designs	5
Roof/Ceiling Designs	6
Installation - Grid	7
Installation – Suspension	8
Installation – Perimeter Wall Angles	8
Installation – Acoustical Ceiling panels	9
Installation – Penetrations	9
Lighting	10
Seismic Design	10
General Information	11

The Fire Resistance Rating of a building assembly (walls, floor/ceiling etc) refers to the period of time the assembly will serve as a barrier to the spread of a fully developed blaze. It also refers to how long the assembly can function structurally after it is exposed to a fire of standard intensity as defined by Standard AS1530.4. The results of the fire test may be used to directly assess fire hazard, but it should be recognized that a single test method will not provide a full assessment of fire hazard under all fire conditions.

USG Fire Rated Grid

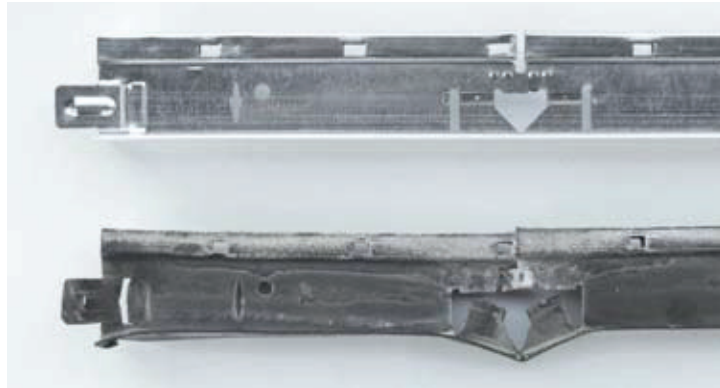

As Installed

After fire

During a fire, the DONN DXL™ main tee notch and engineered design of the patented high tensile QRC tab of the DX heavy weight cross tees, allow a controlled collapse from thermal expansion.

This prevents the unpredictable twisting, bending and bowing extreme heat can produce on non-fire rated steel grid. In causing the ceiling system to tighten, the ceiling remains flat to prevent ceiling panels dropping, or gaps occurring at edges, and therefore maintain the fire resistant integrity of the ceiling system avoiding injury, obstruction or decreased structure protection.

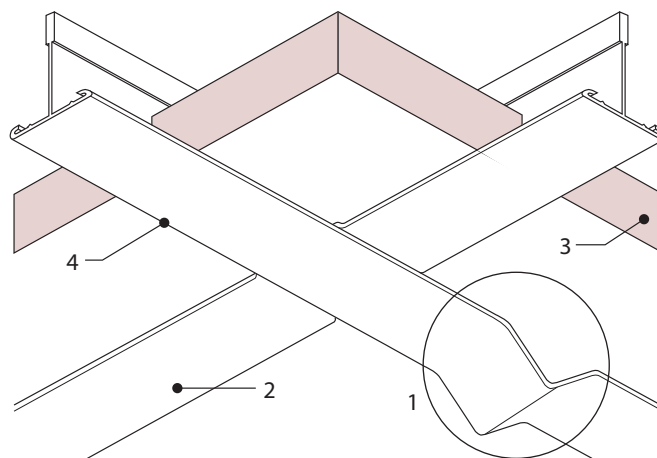

1. Controlled expansion
2. DONN Cross tee
3. USG Firecode™ acoustical ceiling panel
4. DONN DXL main tee

USG Fire Rated Acoustical Ceiling Panels

These are non-combustible and are a specific formulation that differs to standard mineral fibre and must be used in a fire rated system to comply. In general, Firecode panels have a high clay content binder which improves their resistance. Additionally, USG Firecode acoustical ceiling panels generally have Early Fire properties:
 AS/NZS 1530.3 of 0,0,0,3 or better.
 AS/NZS 3837 - Group1



Floor/Ceiling Designs

Fire Rating 60/60/60 (Structure/Integrity/Insulation)

Design No.	System Design		BRANZ Test/Opinion	
USGFC-61	Timber Floor Timber Joists 	Floor 20mm flooring grade particle board or 18mm minimum T & G, or 18mm minimum plywood Joist 250 x 50mm radiata pine, Grade F5, kiln dried Alternative 250 x 50mm joists Softwood – 440kg/m ³ density, minimum Hardwood – 500kg/m ³ density, minimum	T O O T O O O	FR2404 97/1166 97/1166 FR2404 97/1166 97/1166 97/1166
USGFC-62	Reinforced Concrete Floor 		O	97/1166
USGFC-63	Reinforced Concrete or Prestressed Concrete Joists 	Flooring options as per USGFC-61 20mm minimum cover to reinforcing	O	97/1166
	Timber and Steel Joists Twinplate and Posi-Strut joists may be substituted provided: <ul style="list-style-type: none"> - the ratio of applied test load to design ultimate load is not less than the joists in FR2404 - the char rate of the timber components is not greater than the tested Radiata pine. 		O	97/1166

Fire Rating 45/45/45

Design No.	System Design		BRANZ Test/Opinion	
USGFC-41	Concrete Floor Steel Joists	The Speedfloor steel joist/concrete floor must be constructed as tested to FR2392	O	FAR1938

Fire Rating 30/30/30

Design No.	System Design		BRANZ Test/Opinion	
USGFC-31	Timber Floor Timber Joists 	Flooring options as per USGFC-61 No constraint on joist or timber type – to suit load requirements	O	97/1166
USGFC-32	Timber Floor Steel Joists 	Flooring options as per USGFC-61 No constraint on steel joist type – to suit load requirements	O	97/1166

1. Floors must be separately designed for non-fire design loads at normal ambient temperatures. The greater of load design or fire resistance design shall be used.

Roof²/Ceiling Designs

Fire Rating 60/60/60

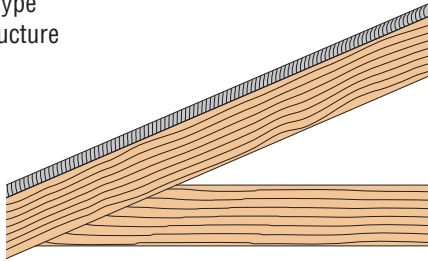
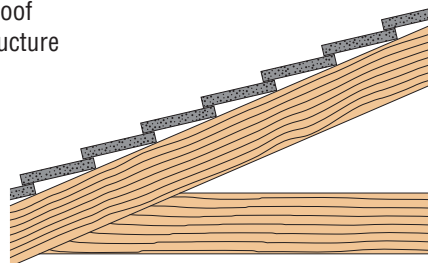
Design No.	System Design	BRANZ Test/Opinion
USGRC-61	<p>Any Roof Type Timber Structure</p>  <p>18mm timber sarking minimum</p> <p>Joist or bottom chord 250 x 50mm minimum or 100 x 50mm if roof space not useable for storage</p>	<p>0 97/1166</p>
USGRC-62	<p>Concrete Roof Timber Structure</p>  <p>Solid concrete, or concrete tile roof</p> <p>Timber structure as above, minimum</p>	<p>0 97/1166</p>

Fire Rating 30/30/30

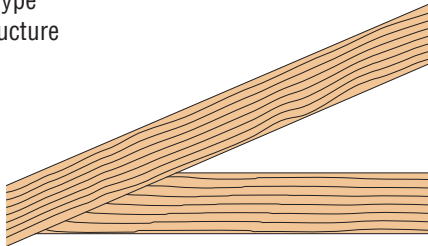
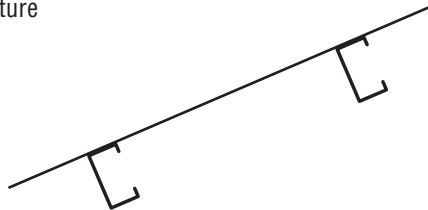
Design No.	System Design	BRANZ Test/Opinion
USGRC-31	<p>Any Roof Type Timber Structure</p>  <p>Joist or bottom chord may be different timber type, spacing or size – to suit load requirements</p>	<p>0 97/1166</p>
USGRC-32	<p>Any Roof Type Steel Structure</p>  <p>No constraint on steel joist/purlin type – to suit load requirements</p>	<p>0 97/1166</p>

2. Important Notes

Loads – Unless the roof and ceiling members have been specifically designed to carry storage loads, they are not required to carry load beyond the self weight of the system during a fire test. They have been tested to carry a significant live load per NZS 4203 : 1992 and NZS 3603 : 1993. Consideration shall be given to other roof load requirements (wind/snow) and the roof structure shall be the greater of the fire resistance or other load requirements.

Insulation – If insulation is required, it is **not** to be overlaid on the ceiling as this will **nullify the fire rating**. It should be kept as close to the roof as possible, the area adequately vented and incorporate a vapor retarder to prevent condensation.

Installation

USG Fire Rated Exposed Grid

General installation, shall comply with USG Interiors installation 'Requirements and Good Design Practice'.

1. USG DONN DXL38D-3600 Main Tee
2. USG DONN DX38D-1200 Cross Tee
3. USG DONN MT55-3600 Perimeter Trim (or US-3600 Seismic Channel)
4. Steel Hold Down Clip
5. $\varnothing 2.5\text{mm}$ Hanger Wire minimum
6. USG Firecode Acoustical Panel

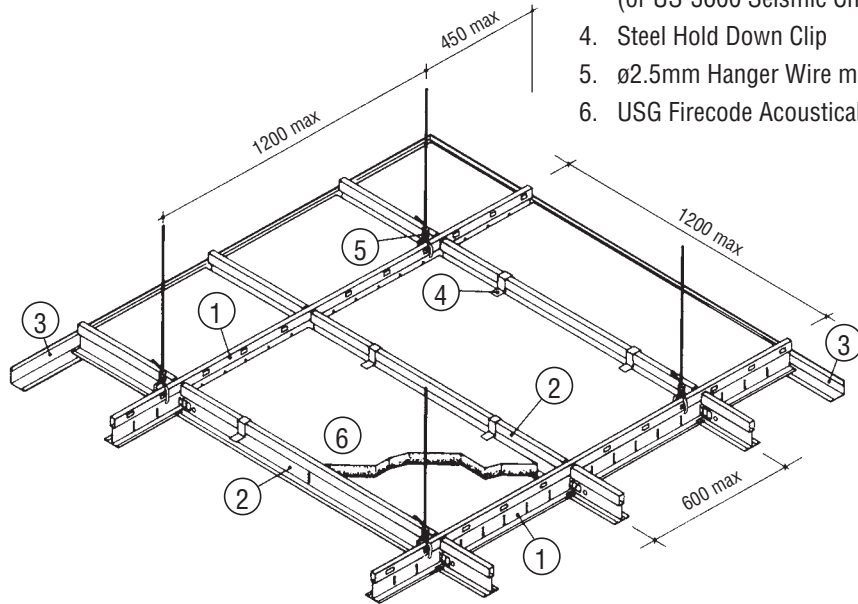

Specific requirements:

- Main tee shall be USG DONN DXL38D-3600
- Cross tee(s) shall be USG DONN DX38D-1200 and/or DX30D-600 when a 600 x 600mm module is specified
- Install fire rated DONN DXL main tees so expansion notches are spaced every 3.6m. **Do not** install notches adjacent to each other.

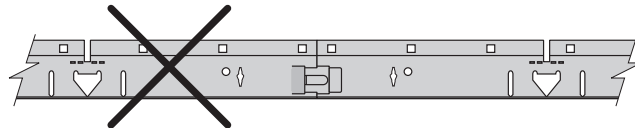

Do not install notches adjacent to each other

- Main tee shall be at 1200mm centres maximum
- DX38D-1200 cross tees shall be at 600mm centres maximum (cross noggled construction is not permitted)
- Depth of plenum shall be:
 FRR 60/60/60 – 450mm minimum from face of grid to underside of floor. For FRR 60/60/60 Roof/Ceiling designs with a horizontal ceiling and a sloping roof, a minimum average of 450mm plenum depth is allowable.
 FRR 30/30/30 – 80mm minimum from face of grid to underside of structure

Allowable installation layouts

KEY	
—	DXL38D-3600
—	DX38D-1200
—	DX30D-600

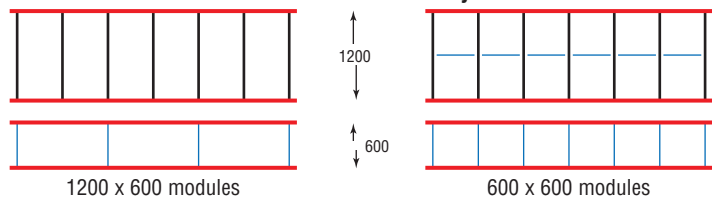

Installation

Suspension

- 2.5mm diameter hanger wire shall be used and attached to the DONN DXL main tee through the web holes only. Ends are to be wound off three tight, 360° turns minimum. **Do not use bulb convenience holes or suspension clips.**
- Suspension must be at 1200 centres maximum.
- Provide a suspension hanger within 200mm of main tee expansion notch and connecting splice.
- Attachment of hanger wire to top structure fastener must also be three tight 360° turns minimum.

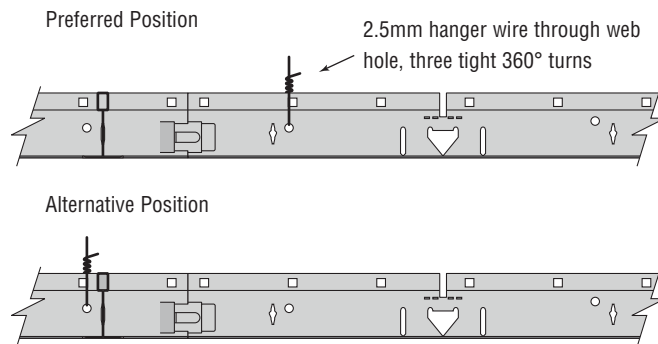

Perimeter Wall Angles

- DONN MT55-3600 22 x 19 mm or US-3600 Seismic Channel shall be used.
- Fixing of wall angles to wall shall use steel fasteners only.
- Fixing centres are to be 600 mm o.c maximum, 50mm from ends maximum (comment: although the MT55-3600 was attached at 600 mm centres for test evaluation, it is recommended to use closer spacing to minimise potential buckling).
- Butt joints were used at corners.
- Attachment of grid components to wall angle shall use steel rivets only (Note: steel type, size and quantity may be determined by seismic restraint requirements - ref *USG Seismic Design Guide*).
- Main and cross tees are to sit flush on the wall angles. Do not use the crimping method to joggle tee ends or any type of infill block for rebated USG Firecode acoustical ceiling panels. Where rebated ceiling panels are specified, field rebating of perimeter panels will be required to maintain ceiling fire insulation.

Details

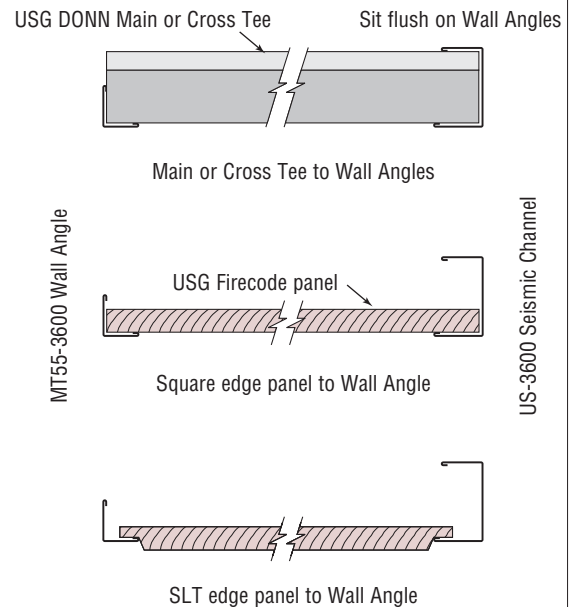

Installation

Fire Rated Acoustical Ceiling Panels

- Ceiling panels must be USG Firecode type FR-83, M, FR-4. This can include, but is not limited to:
 - USG Radar ClimaPlus Firecode
 - USG Radar ClimaPlus High NRC
 - USG Radar ClimaPlus High CAC
 - USG Clean Room ClimaPlus
 - USG Rock Face ClimaPlus
 - Square edge (SQ) or rebated Shadowline (SLT) may be used depending on options available.
 - 1200 x 600 or 600 x 600mm sizes can be used.
- Consult your regional USG ceiling specialist for local availability.

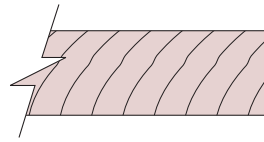

SQ

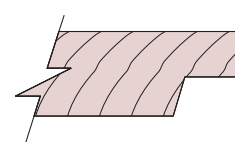

SLT

Clipping of Acoustical Panels

- Clips shall be used to increase resistance to unintentional dislodgement, or extreme pressure in a fire situation.
- Where access to specific locations in the plenum is desired, clips can be trimmed on the accessible panel side while still retaining the adjacent panel.
- Only steel clips are to be used such as L15 or similar.

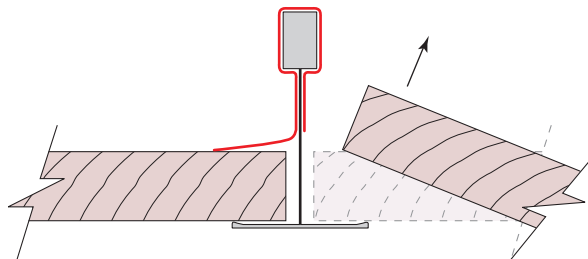

Penetrations

- Any service penetrations through the fire rated constructions covered in this brochure must be fire stopped by approved methods in accordance with NZBC requirements, Control of Internal Fire and Smoke Spread C/AS1 Part 6.0.

In particular attention is drawn to:

- Clause 6.17.2 where firestops shall have a FRR no less than the fire separation assembly in which they are installed.
- Clause 6.17.7 penetrations are to be supported to resist movement or collapse during a fire to avoid failure of the seal. The support system shall not prevent normal expansion or contraction of the penetration.
- In addition penetrations and seals must not inhibit the controlled grid movement during a fire. Any penetrations must be supported independently from the grid or panels and are not to impose additional loads on either (except lights as page 10).
- Any penetration hardware shall have a FRR no less than the USG Fire rated ceiling system. If different, the lesser of the FRR's shall apply.

Installation

Lighting

- Proprietary lighting options as listed are suitable for use with USG fire rated ceiling systems.
- Testing of these products was not conducted by USG Interiors Pacific Limited. For specific details, installation and limitations, consult the fitting supplier.
- These, or any approved alternatives, are not be supported by the acoustical ceiling panels. Their load shall be transferred back to the exposed grid by steel supports as examples a) and b) below. All other installation details shall comply with the suppliers requirements and relevant clauses under Penetrations.

Light Type	FRR	Company
Downlight - incandescent SDF125	60/60/60	Gartner Superlux Ltd PO Box 13-441, Onehunga, Auckland Phone 09-636-6092 Fax 09-634-6802

a) Simple supports across the back of the ceiling panel.

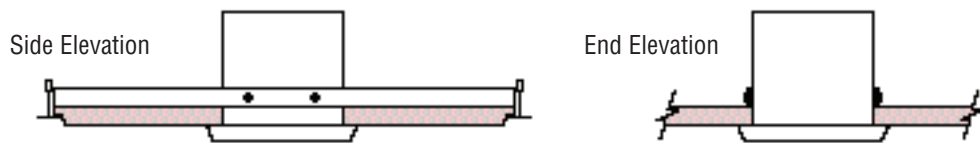

b) Simple supports onto the top the tee bulb.

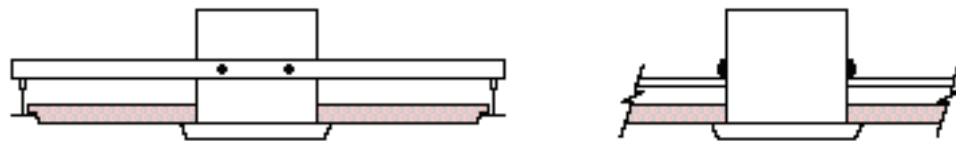

Seismic Design

USG fire rated ceilings shall be subject to the same seismic restraint criteria as standard USG DONN exposed grid systems. Refer to USG's Seismic Design Guide.

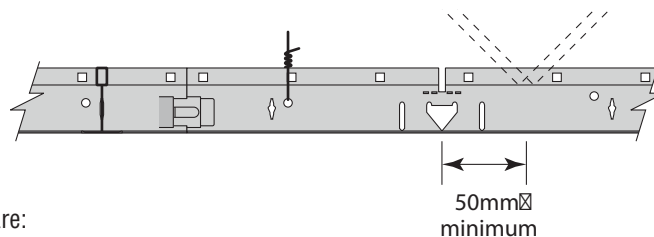

Additional requirements are:

- When perimeter fixing, use steel fasteners only (not aluminium)
- When back-bracing is required, braces shall be at 3.6 metre centres in **main tee** direction. For different line loads, vary the type of brace product to suit the load. Cross tee direction brace spacing can vary to suit line load requirements.
- If line loads exceed standard bracing products, a specific design will be required – contact USG Interiors Pacific Ltd.
- For back-brace fixing, use steel fasteners only (not aluminium).
- Braces shall not be connected within 50mm of the fire rating notch of the main tee.



Fire Rating

Acoustical Ceiling Systems

Health and Safety	When handling, take care and ensure that safe work practices are adhered to at all times. Some products may have surface treatments and sharp edges/ends. All reasonable care should be taken when handling or installing to avoid any potential injury to self or others. Users should be properly trained and supervised in the use and handling of these materials. Appropriate personal protective equipment should be used when necessary eg: gloves/glasses etc, to avoid any potential injuries.
Handling and Storage	Store materials on a flat, dry surface and handle/store in a manner that will prevent distortion, scratches or damage of any kind by/to other trades.
Notes	<ul style="list-style-type: none">• In accordance with USG's policy of continuous product improvement, we reserve the right to alter specifications without prior notice• All sizes and weights are nominal• This document has been prepared on reliance of the professional testing, advice and services provided by independent specialist organisations, and USG Interiors Pacific Ltd believes the contents of this brochure to be correct at the time of printing. Whilst all care has been taken to ensure accuracy, except to the extent prohibited by law, no liability is accepted for any claim by any person, whether for loss of profits or for any other direct, consequential, indirect or special loss, damage or injury suffered by any person, and whether arising from any negligence or omission on the part of any person or otherwise directly or indirectly from the use of the information contained in this document.
Trademarks	The following are the registered or unregistered trademarks of USG Corporation or a related company: USG, DONN, DX, DXL Firecode.



IN THE EVENT OF
FIRE, DO NOT USE
THE ELEVATOR

USE THE STAIRS

To request literature, samples, a visit from a
USG Ceilings specialist, or for all technical
questions, call your nearest USG office below.



USG Australasia

© 2011

New South Wales

Phone:

Fax:

1800 226 215

1800 786 946

Queensland

Victoria

Auckland Head Office

Phone: (09) 270-2595

Fax: (09) 270-1799

Wellington

(04) 560 4528

(04) 560 4529

FR/6-11

email: info-anz@usg.co.nz or

www.usg.co.nz